

UNIVERSAL PIPELINE CONNECTORS UCX90

DESCRIPTION

The UCX series pipeline connectors are used in steam systems where a simple and economic maintenance program is desired. Typical installations are drip service on steam lines, tracing applications and small process equipment. The four-bolt flange connector allows for fast trap replacement without disturbing the pipelines. The UCX connector fits the universal four-bolt swivel connection steam traps.

MAIN FEATURES

Remains permanently in-line making the replacement of new traps easier and quicker. Steam traps can swivel 360°, allowing any pipe orientation during installation. The universal flange allows the trap to be positioned in the correct position, regardless of pipeline configuration. Built-in strainer.

- OPTIONS:** Blowdown valve.
- USE:** Saturated and superheated steam.
- AVAILABLE MODELS:** UCX90 – stainless steel.
- SIZES:** 1/2" to 1"; DN 15 to DN 25.
- CONNECTIONS:** Female threaded ISO 7 Rp or NPT.
Flanged EN 1092-1 PN 100.
Flanged ASME B16.5 Class 600.
Socket weld (SW) ASME B16.11.

INSTALLATION: With the surface for swivel connection in a vertical plane (mechanical steam traps) or, alternatively, in an horizontal plane for thermostatic steam traps. See IMI – Installation and maintenance instructions.



BODY LIMITING CONDITIONS		
FLANGED PN 100 *	FLANGED CLASS 600 **	RELATED TEMP.
ALLOWABLE PRESSURE	ALLOWABLE PRESSURE	
100 bar	100 bar	50 °C
100 bar	92,7 bar	250 °C
97,6 bar	80,4 bar	350 °C
88 bar	67,7 bar	450 °C

Operating pressure: 4 to 85 bar.
* Acc. to EN 1092-1:2018. ** Acc. to EN 1759-1:2004.
Body limiting conditions PN 100 or below, depending on the type of connection adopted. Rating PN 100 for threaded and SW versions.

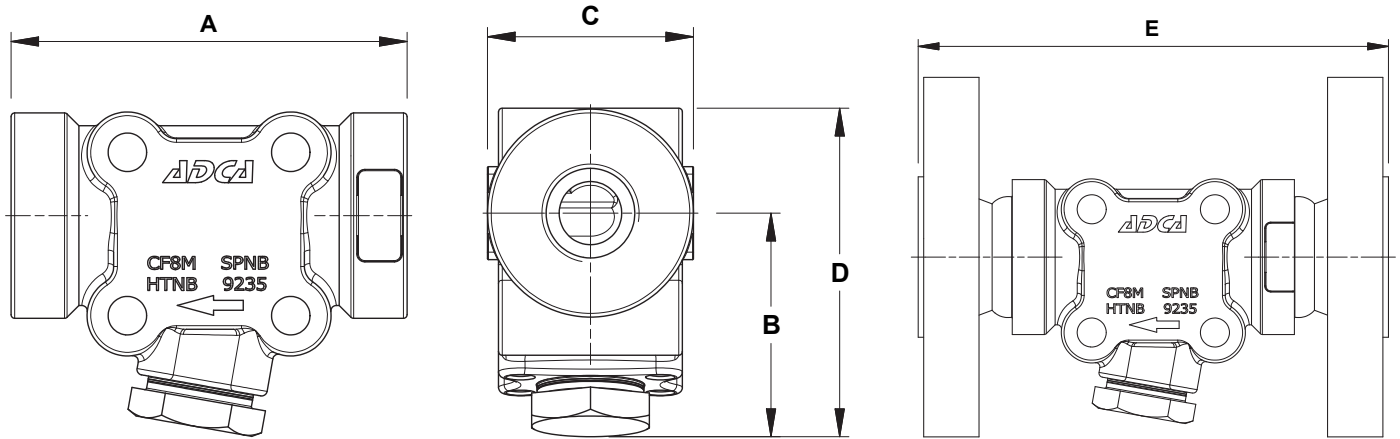

DIMENSIONS (mm)									
SIZE	THREADED / SW				WEIGHT (kg)	PN 100		CLASS 600	
	A	B	C	D		E	WEIGHT (kg)	E	WEIGHT (kg)
1/2" - DN 15	108	60	56	88	2,1	165	4,4	185	3,8
3/4" - DN 20	108	60	68	88	2,1	170	6	200	4,9
1" - DN 25	108	60	68	88	2	185	7,1	200	5,5

MATERIALS		
POS. N°	DESCRIPTION	MATERIAL
1	Body	A351 CF8M / 1.4408
2	Strainer cap	AISI 321 / 1.4541
3	* Strainer screen	AISI 304 / 1.4301
4	* Spiral wound gasket	Stainless steel / Graphite

* Available spare parts.

