

SANITARY PRESSURE REDUCING VALVE P160G

DESCRIPTION

The ADCAPure P160G is a series of angle design direct acting diaphragm sensing pressure reducing valves. These regulators are designed for use with clean steam, compressed air, water and other gases or liquids compatible with the construction materials and valve design.

MAIN FEATURES

FDA / USP Class VI compliant seals.
Completely machined from bar stock material, no castings or forgings are used.

STANDARD SURFACE FINISH

Internal wetted parts: $\leq 0,51$ micron Ra – SF1.
External: $\leq 0,76$ micron Ra – SF3.
Other surface conditions see IS PV20.00 E – Technical information.
Ultrasonic cleaning.

OPTIONS: Leakage line connection (1/4").
Different soft sealings for liquids and gases.
Lock system, allows inline clean-in-place (CIP) and sterilization-in-place (SIP) operations.
Gauge connection on body.
Lifting lugs to ease installation.

USE: Clean steam, compressed air, water and other gases and liquids compatible with the construction.

AVAILABLE MODELS: P160G.

SIZES: 2 1/2" and 3".

REGULATING RANGES: 1 to 1,7 bar; 1,5 to 4 bar.

CONNECTIONS: ASME BPE clamp ferrules.
Others on request.

PACKAGING: Assembling and packaging in a clean room certified according to ISO 14644-1.
The product is end capped and sealed with recyclable thermo-shrinkable plastic film, to avoid contamination.

INSTALLATION: Horizontal installation. Vertical inlet and horizontal outlet angle connection.
See IMI – Installation and maintenance instructions.



LIMITING CONDITIONS	
Valve model	P160G
Body design conditions	PN 16
Maximum upstream pressure	8 bar
Maximum downstream pressure	4 bar
Minimum downstream pressure *	1 bar
Maximum operating temperature **	180 °C

* For tight shut off, with adjustment spring relaxed, ensure a minimum downstream pressure of 0,2 bar.
** With PTFE diaphragm and seals. Consult the manufacturer in case of other materials.

CE MARKING – GROUP 2 (PED – European Directive)	
PN 16	Category
2 1/2" to 3"	1 (CE Marked)

DIMENSIONS (mm) ASME BPE

SIZE	A	B	C	D	d1	d2	d3	E	F	H	WGT. (kg)
2 1/2"	144	78	410	245	25	15,75	1/4"	141	77,4	60,2	34,6
3"	144	84	417	245	25	15,75	1/4"	141	90,9	72,9	36,2

FLOW RATE COEFFICIENTS (m³/h)

SIZE	2 1/2"	3"
Kvs	19,8	

MATERIALS

POS. N°	DESIGNATION	MATERIAL
1	Valve body	AISI 316L / 1.4404
2	Cover	AISI 316L / 1.4404
3	Centering plate	AISI 316L / 1.4404
4	* Valve stem	AISI 316L / 1.4404
5	* Soft plug	** EPDM; PTFE; FPM
6	* Valve plug	AISI 316L / 1.4404
8	* Diaphragm	PTFE (Gylon)
9	Diaphragm plate	AISI 316L / 1.4404
10	* O-ring	EPDM
11	* O-ring	EPDM
12	* O-ring	EPDM
11	Diaphragm plate	AISI 316L / 1.4404
12	Stem guide	AISI 316 / 1.4401
13	Spring plate	AISI 316 / 1.4401
14	Nut	Stainless steel A2-70
15	Washer	AISI 316 / 1.4401
16	* Adjustment spring	Zinc plated spring steel
17	Top spring plate	AISI 316 / 1.4401
18	Bearing	Corrosion resistant steel
19	Nut	Stainless steel A2-70
20	Adjustment screw	AISI 304 / 1.4301
21	Top cap	AISI 316L / 1.4404
25	Bolts	Stainless steel A2-70

* Available spare parts ; ** Others on request.

Remarks: FDA / USP Class VI seals certificate on request.

All valves have a serial number. In case of non-standard valves, this number must be supplied if spare parts are ordered.

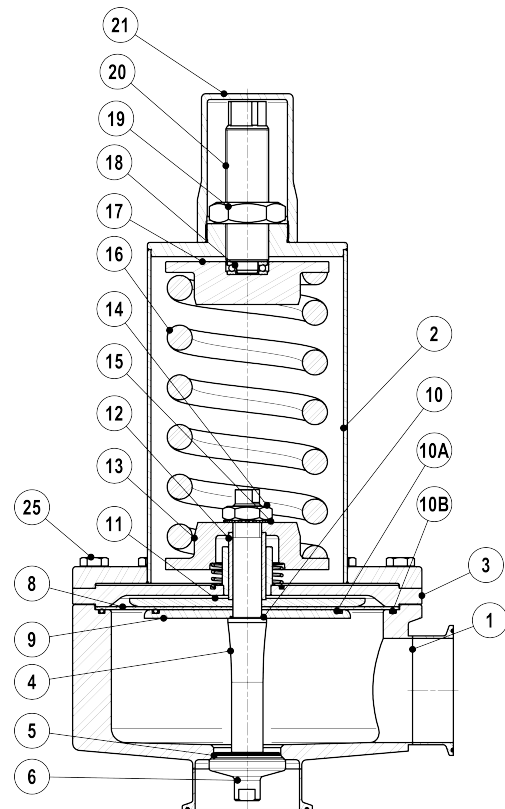
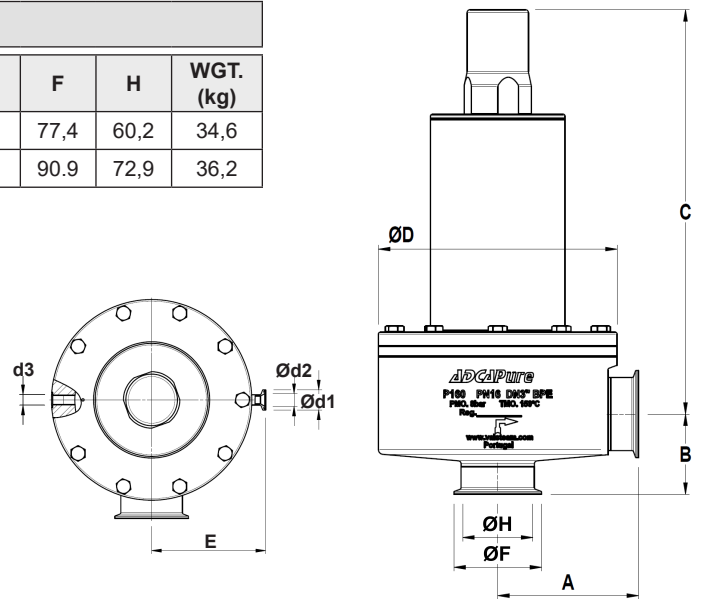

OPTIONS

LOCK SYSTEM	PRESSURE GAUGE CONNECTION	LEAKAGE LINE CONNECTION (1/8")

ORDERING CODES P160G													
Valve model	P16G	8	9	T	M	T	X	X	X	DI	65	E	
P160G – AISI 316L / 1.4404 diaphragm sensing pressure reducing valve	P16G												
Regulating range													
1 to 1,7 bar		8											
1,5 to 4 bar		9											
Flow rate coefficient													
Kvs 19,8			9										
Diaphragm													
PTFE (Gylon)				T									
EPDM (non-standard)				E									
Valve head													
Metal to metal (non-standard)					M								
EPDM					E								
PTFE					T								
FPM / Viton (FDA approval only)					V								
Top cap and leakage line connection													
Top cap (adjustment screw with cover)						T							
Top cap (adjustment screw with cover) w/ diaphragm cover leakage connection in case of diaphragm failure						U							
Gauge port options													
Without gauge ports								X					
Tri-clamp gauge port on the left side (rel. to the flow direction) – downstream pressure								7					
Tri-clamp gauge port on the right side (rel. to the flow direction) – downstream pressure								6					
Tri-clamp gauge port on both sides – downstream pressure								5					
Threaded gauge port on the left side (rel. to the flow direction) – downstream pressure – ISO 7 Rp 1/4"								4					
Threaded gauge port on the right side (rel. to the flow direction) – downstream pressure – ISO 7 Rp 1/4"								3					
Threaded gauge port on both sides – downstream pressure – ISO 7 Rp 1/4"								2					
Threaded gauge port on the left side (rel. to the flow direction) – downstream pressure – 1/4" NPT								W					
Threaded gauge port on the right side (rel. to the flow direction) – downstream pressure – 1/4" NPT								Y					
Threaded gauge port on both sides – Downstream pressure – 1/4" NPT								Z					
Surface finish a)													
Standard surface finish									X				
Mirror mechanical polished external surfaces (SF1)									P				
Electropolished internal wetted parts (SF5)									E				
Special features													
None										X			
Degreased for oxygen										O			
CIP / SIP lock system										C			
Pipe connections													
Clamp ferrule ASME BPE											D		
Tube weld (ETO) according to ASME BPE											DI		
Size													
2 1/2"											65		
3"											80		
Special valves / Extras													
Full description or additional codes have to be added in case of a non-standard combination												E	

a) Consult IS PV20.00 – Technical information – for further details and other surface finish options.