

SANITARY PRESSURE REDUCING VALVES P130H

DESCRIPTION

The ADCAPure P130H is a series of direct acting, diaphragm sensing, balanced plug pressure reducing valves.

These regulators, available with spring or dome-loading, are designed for use with clean air, nitrogen, carbon dioxide, oxygen, argon and other gases or liquids compatible with the construction materials and valve design.

Specifically designed for the high purity gas systems found in the pharmaceutical, cosmetic, fine chemical and food & beverage processes.

MAIN FEATURES

- Compact design.
- Non-rising adjustment knob.
- FDA / USP Class VI compliant seals.
- Completely machined from 316L stainless steel bar stock, no castings or forgings are used.

STANDARD SURFACE FINISH

- Internal wetted parts: $\leq 0,51$ micron Ra – SF1.
- External: $\leq 0,76$ micron Ra – SF3.
- Other surface conditions see IS PV20.00 E – Technical information.
- Ultrasonic cleaning.

- OPTIONS:
- Leakage line connection.
 - Dome-loading.
 - Top cap (adjustment screw with cover).
 - Gauge connection on body.
 - Different soft sealings for liquids and gases.
 - Degreased for oxygen application.

- USE:
- Clean air, nitrogen, carbon dioxide, oxygen, argon and other gases or liquids compatible with the construction.

- AVAILABLE MODELS:
- P130H.

- SIZES:
- 1"; DN 25.

- REGULATING RANGES:
- 0,2 to 1,5 bar; 0,3 to 3 bar; 2 to 8 bar.

- CONNECTIONS:
- ASME BPE, DIN and ISO clamp ferrules or tube weld (ETO) ends. Others on request.

- PACKAGING:
- Assembling and packaging in a clean room certified according to ISO 14644-1.
 - The product is end capped and sealed with recyclable thermo-shrinkable plastic film, to avoid contamination.

- INSTALLATION:
- Horizontal installation is recommended.
 - See IMI – Installation and maintenance instructions.

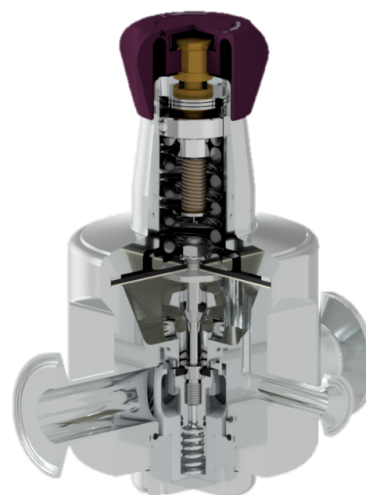

LIMITING CONDITIONS	
Valve model	P130H
Body design conditions	PN 16
Maximum upstream pressure	16 bar
Maximum downstream pressure	8 bar
Minimum downstream pressure	0,2 bar
Maximum design temperature *	150 °C

* Others on request.

CE MARKING – GROUP 2 (PED – European Directive)	
PN 16	Category
All sizes	SEP

FLOW RATE COEFFICIENTS (m ³ /h)						
	ASME BPE		DIN		ISO	
SIZE	1"		DN 25		DN 25	
Kvs	3,2	4,2	3,2	4,2	3,2	4,2

OPTIONS			
LEAKAGE LINE CONNECTION	DOME-LOADING	TOP CAP	PRESSURE GAUGE CONNECTION

DIMENSIONS

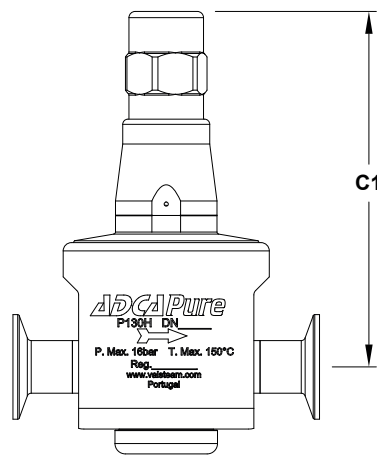
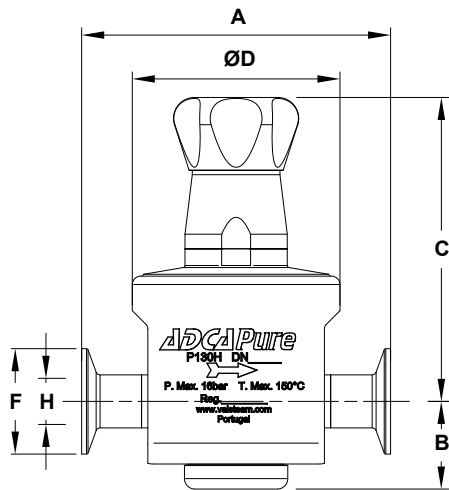

Optional top cap

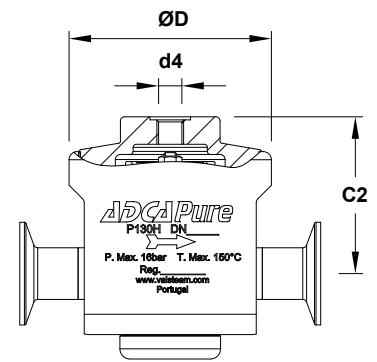

Optional dome-loading

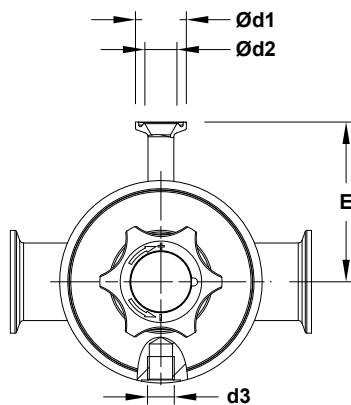

Optional gauge connection

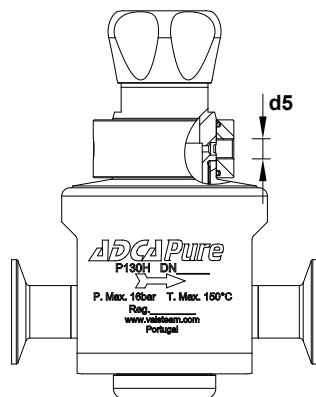

Optional leakage line connection

DIMENSIONS – ASME BPE (mm)

SIZE	A	B	C	C1	C2	ØD	Ød1	Ød2	d3	d4	d5	E	ØF	ØH	WGT. (kg) *
1"	148	42	146	171,6	77,1	100	25	15,75	1/4"	1/4"	1/8"	78,5	50,5	22,1	5,14

* Valves with nylon adjustment knob weigh 0,3 kg less.

DIMENSIONS – DIN (mm)

SIZE	A	B	C	C1	C2	ØD	Ød1	Ød2	d3	d4	d5	E	ØF	ØH	WGT. (kg) *
DN 25	135	42	146	171,6	77,1	100	25	15,75	1/4"	1/4"	1/8"	78,5	50,5	26	5,17

* Valves with nylon adjustment knob weigh 0,3 kg less.

Remarks: Clamp ferrules according to DIN 32676-A. Tube weld (ETO) according to DIN 11866-A (DIN 11850-2).

DIMENSIONS – ISO (mm)

SIZE	A	B	C	C1	C2	ØD	Ød1	Ød2	d3	d4	d5	E	F	H	WGT. (kg) *
DN 25	135	46	142	171,6	73,1	100	25	15,75	1/4"	1/4"	1/8"	78,5	50,5	29,7	5,16

* Valves with nylon adjustment knob weigh 0,3 kg less.

Remarks: Clamp ferrules according to DIN 32676-B. Tube weld (ETO) according to DIN 11866-B (ISO 1127).

MATERIALS

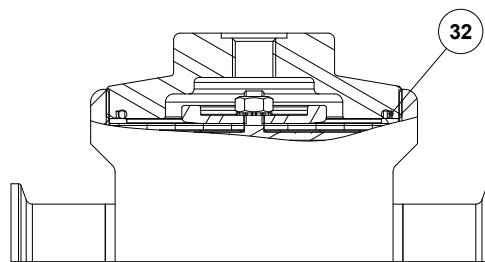
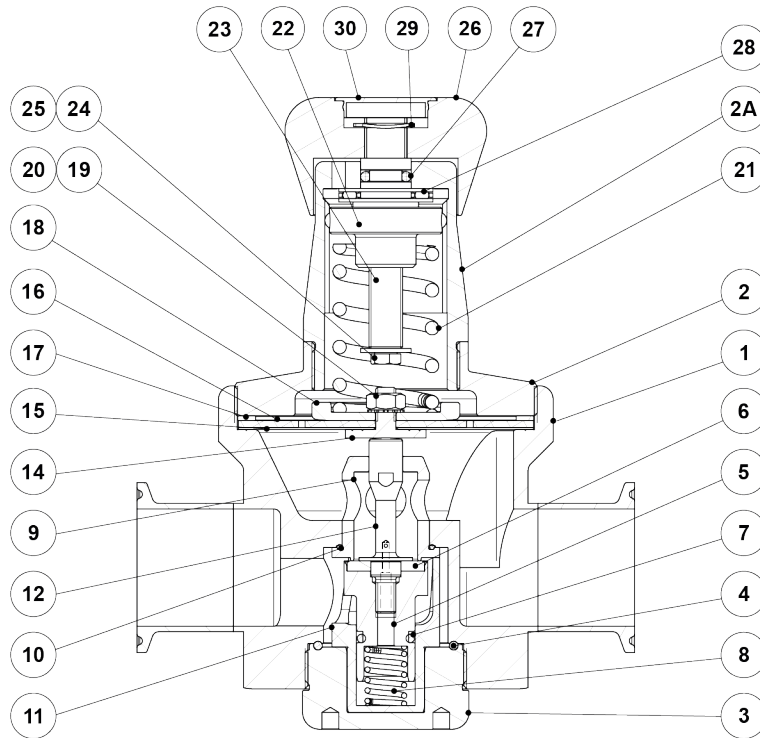

Optional dome-loading

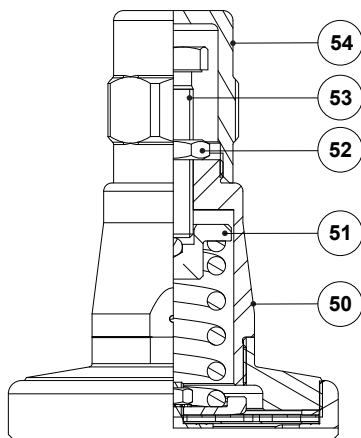

Optional top cap

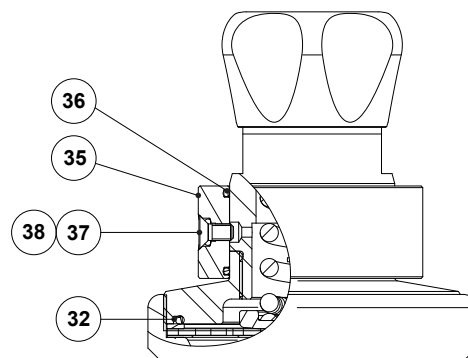

Optional leakage line connection

MATERIALS

POS. N°	DESIGNATION	MATERIAL
1	Valve body	AISI 316L / 1.4404
2	Cover	AISI 316L / 1.4404
2A	Spring cover	AISI 316L / 1.4404
3	Bottom cover	AISI 316L / 1.4404
4	* O-ring	** EPDM
5	* Piston	AISI 316L / 1.4404
6	* Valve head	** EPDM; PTFE; FPM
7	* O-ring	** EPDM
8	* Valve spring	AISI 316 / 1.4401 electropolished
9	* Seat	AISI 316L / 1.4404
10	* O-ring	** EPDM
11	Guide	AISI 316L / 1.4404
12	* Stem	AISI 316L / 1.4404
14	* Pusher disk	AISI 316L / 1.4404
15	* Lower diaphragm	PTFE (Gylon)
16	* Upper diaphragm	EPDM
17	Washer	AISI 304 / 1.4301
18	* Plate	AISI 304 / 1.4301
19	* Nut	Stainless steel A2-70
20	* Serrated washer	AISI 304 / 1.4301
21	* Adjustment spring	AISI 302 / 1.4300
22	Spring guide	AISI 316 / 1.4401
23	Adjustment screw	Brass
24	Washer	Stainless steel A2
25	Bolt	Stainless steel A2-70
26	Adjustment knob	AISI 316L / 1.4404 or Nylon
27	O-ring	NBR
28	Bearing	Corrosion resistant steel
29	Shaft ring	Stainless steel
30	Cover nut	Plastic
32	* O-ring	EPDM
35	Leakage line ring	AISI 316 / 1.4401
36	O-ring	NBR
37	Bolt	AISI 304 / 1.4301
38	O-ring	FPM
50	Cover	AISI 316L / 1.4404
51	Spring guide	Brass
52	Lock nut	Stainless steel A2
53	Adjustment screw	Stainless steel A2-70
54	Top cap	AISI 316L / 1.4404

* Available spare parts. ** Others on request.

Remarks: FDA / USP Class VI seals certificate on request.

All valves have a serial number. In case of non-standard valves, this number must be supplied if spare parts are ordered.

ORDERING CODES P130H													
Valve model	P3H	1	2	T	M	X	I	X	X	X	DI	25	
P130H – AISI 316L / 1.4404 diaphragm sensing pressure reducing valve	P3H												
Regulating range													
0,2 to 1,5 bar		1											
0,3 to 3 bar		2											
2 to 8 bar		3											
0,2 to 8 bar (dome-loaded) a)		A											
Flow rate coefficient													
Kvs 3,2		1											
Kvs 4,2		2											
Diaphragm													
PTFE (Gylon)				T									
EPDM (non-standard)				E									
Seat material													
Metal to metal (non-standard)					M								
EPDM					E								
PTFE					T								
FPM / Viton (USP Class VI on request)					V								
Leakage line connection													
Without leakage line connection						X							
Leakage line connection – ISO 228 G 1/8"						N							
Leakage line connection – 1/8" NPT						C							
Adjustment knob and top cap													
Stainless steel adjustment knob							I						
Nylon adjustment knob							P						
Top cap (adjustment screw with cover)							T						
Dome-loading – ISO 228 G 1/4" b)							X						
Dome-loading – 1/4" NPT b)							C						
Gauge ports													
Without gauge ports								X					
Tri-clamp gauge port on the left side (rel. to the flow direction) – downstream pressure									7				
Tri-clamp gauge port on the right side (rel. to the flow direction) – downstream pressure										6			
Tri-clamp gauge port on both sides – downstream pressure											5		
Threaded gauge port on the left side (rel. to the flow direction) – downstream pressure – ISO 228 G 1/4"												4	
Threaded gauge port on the right side (rel. to the flow direction) – downstream pressure – ISO 228 G 1/4"													3
Threaded gauge port on both sides – downstream pressure – ISO 228 G 1/4"													2
Threaded gauge port on the left side (rel. to the flow direction) – downstream pressure – 1/4" NPT													W
Threaded gauge port on the right side (rel. to the flow direction) – downstream pressure – 1/4" NPT													Y
Threaded gauge port on both sides – downstream pressure – 1/4" NPT													Z
Surface finish c)													
Standard surface finish												X	
Mirror mechanical polished external surfaces (SF1)													P
Electropolished internal wetted parts (SF5)													E
Special features													
None													X
Degreased for oxygen													O
Pipe connection													
Clamp ferrule ASME BPE													D
Clamp ferrule DIN (DIN 32676-A)													F
Clamp ferrule ISO (DIN 32676-B)													E
Tube weld (ETO) according to ASME BPE													DI
Tube weld (ETO) according to DIN 11866-A (DIN 11850-2)													FI
Tube weld (ETO) according to DIN 11866-B (ISO 1127)													EI
Size													
1" or DN 25													25
Special valves / Extras													
Full description or additional codes have to be added in case of non-standard combination													E

a) The loading control pressure can be up to a maximum of 1,2 bar above the required downstream pressure. **b)** Mandatory in case of dome-loading. **c)** Consult IS PV20.00 for further details and other surface finish options.