

SANITARY PRESSURE SUSTAINING VALVE
In-line design
PS173

DESCRIPTION

The ADCA PS173 series direct acting, spring-loaded diaphragm sensing, pressure sustaining valves are designed for use with clean steam, compressed air, water and other gases or liquids compatible with the construction materials.

MAIN FEATURES

Compact in-line design.
Completely machined from bar stock material, no castings or forgings are used on the standard version.
FDA/USP Class VI compliant seals.
No rising stem.

STANDARD SURFACE FINISH

Internal wetted parts: ≤ 0,51 micron Ra – SF1.
External: ≤ 0,76 micron Ra – SF3.
Other surface conditions see IS PV20.00 E – Technical information.
Ultrasonic cleaning.

OPTIONS: Leakage line connection 1/8" (captured vent).
Different soft valves for liquids and gases.
Gauge connection on body.
With or without bottom drain connection.

USE: Clean steam, compressed air, water and other gases and liquids compatible with the construction.

AVAILABLE MODELS: PS173.

SIZES: 1 1/2", 2" ; DN 32 to DN 50.

OUTLET RANGE: 0,8 – 1,5 bar; 1 – 3 bar; 1,5 – 8 bar.

CONNECTIONS: Clamp ferrules or others on request.

PACKAGING: Assembling and packaging in a clean room certified according to ISO 14644-1.
The product is end capped and sealed with recyclable thermo-shrinkable plastic film, to avoid contamination.

INSTALLATION: Horizontal installation. See IMI – Installation and maintenance instructions.

ORDER

REQUIREMENTS: Type of fluid.
Maximum operating temperature.
Inlet pressure and required outlet pressure
Capacity (maximum and minimum).



LIMITING CONDITIONS	
Valve model	PS173
Body design conditions	PN16
Max. upstream pressure	8 bar
Min. downstream pressure	0,8 bar
Max. design temperature *	150 °C

* Others on request.

CE MARKING – GROUP 2 (PED – European Directive)	
PN16	Category
1 1/2"; 2"; DN 32 to DN 50	SEP

CAPACITIES

Valve size	BPE		DIN		ISO	
	1 1/2"	2"	40	50	32	40
Kvs	5,5	8,5	5,5	8,5	5,5	8,5

DIMENSIONS (mm) ASME BPE

SIZE	A	B	B1	C	D	d1	d2	E	F	H	NPS 1/2"		WGT. (kg)
											F1	H1	
1 1/2"	170	94	70	199	130	25	15,75	90	50,5	34,8	25	9,4	8,6
2"	170	99	76	205	130	25	15,75	90	64	47,5	25	9,4	8,9

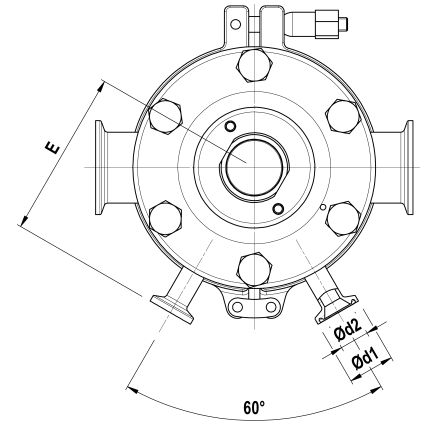

DIMENSIONS (mm) DIN

SIZE	A	B	B1	C	D	d1	d2	E	F	H	DN 15		WGT. (kg)
											F1	H1	
DN 40	170	94	70	199	130	25	15,75	90	50,5	38	34	10	8,6
DN 50	170	99	76	205	130	25	15,75	90	64	50	34	10	8,9

Clamp ferrules DIN 32676 Series A; Tube weld DIN 11866 Series A (DIN 11850 Series 2).

DIMENSIONS (mm) ISO

SIZE	A	B	B1	C	D	d1	d2	E	F	H	DN 15		WGT. (kg)
											F1	H1	
DN 32	170	93	70	199	130	25	15,75	90	64	38,4	25	10,3	8,6
DN 40	170	99	76	205	130	25	15,75	90	64	44,3	25	10,3	9,2

Clamp ferrules DIN 32676 Series B; Tube weld DIN 11866 Series B (ISO 1127 Series 1).

Remarks: Special versions or non-standard sanitary clamp ferrules are available on request, both for the inlet/outlet, pressure gauge and drain connections.

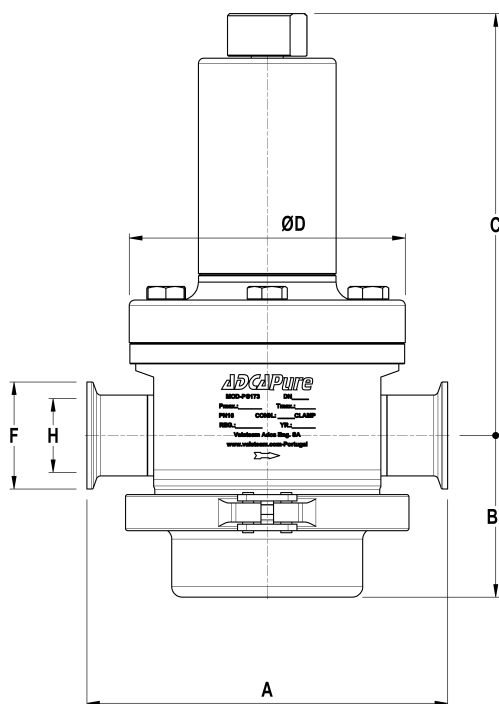

Valve without bottom connection.

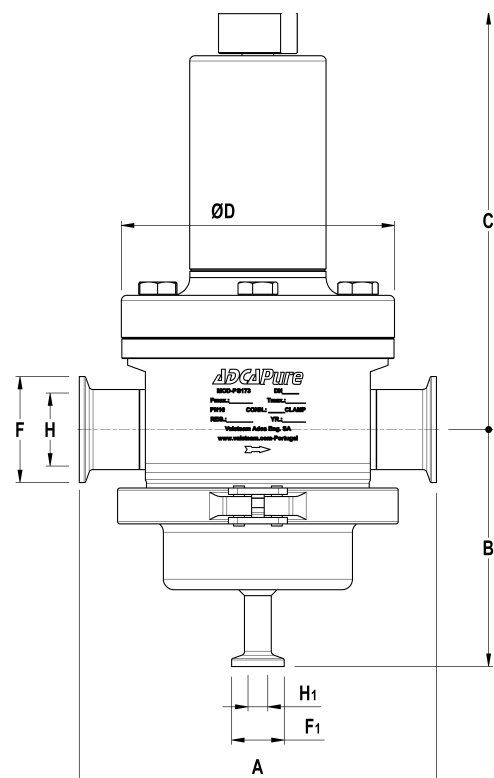

Valve with connection for condensate drainage.

MATERIALS

POS. N°	DESIGNATION	MATERIAL
1	Valve body	AISI 316L / 1.4404
2	Cover	AISI 316L / 1.4404
2.1	Bottom cover	AISI 316L / 1.4404
2.2	Gasket	PTFE / TFM® Envelope gasket
2.3	Safety clamp	AISI 316 / 1.4401
3	Centering plate	AISI 316L / 1.4404
4	* Valve stem	AISI 316L / 1.4404
5	* Soft plug	EPDM; PTFE **
6	* Valve plug	AISI 316L / 1.4404
7	* Upper diaphragm	EPDM
8	* Lower diaphragm	PTFE (Gylon)
9	Diaphragm plate	AISI 316L / 1.4404
10	* O-ring	EPDM
11	Diaphragm plate	AISI 316L / 1.4404
12	Stem guide	AISI 316 / 1.4401
13	Spring plate	AISI 316 / 1.4401
14	Nut	Stainless steel A2-70
15	Washer	AISI 316 / 1.4401
16	* Adjustment spring	AISI 302 / 1.4300
17	Top spring plate	AISI 316 / 1.4401
18	Retaining washer	Stainless steel A2-70
19	Regulating nut	AISI 316L / 1.4404
20	Adjustment screw	Brass
21	O-ring	NBR
22	Bearing	Corrosion resistant steel
23	Ext. bowed shaft ring	Stainless steel
24	Cover nut	Plastic
25	Bolts	A2

* Available spare parts; ** Others according to fluid.

FDA / USP Class VI seals certificate on request.

For viton diaphragm the only approval available is the FDA (pos. 7).

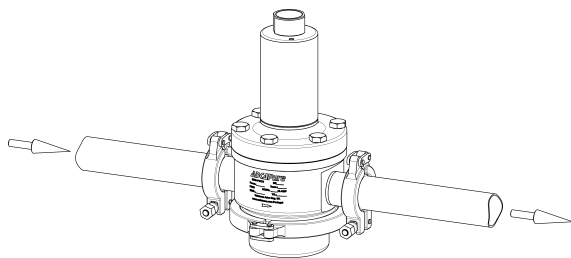
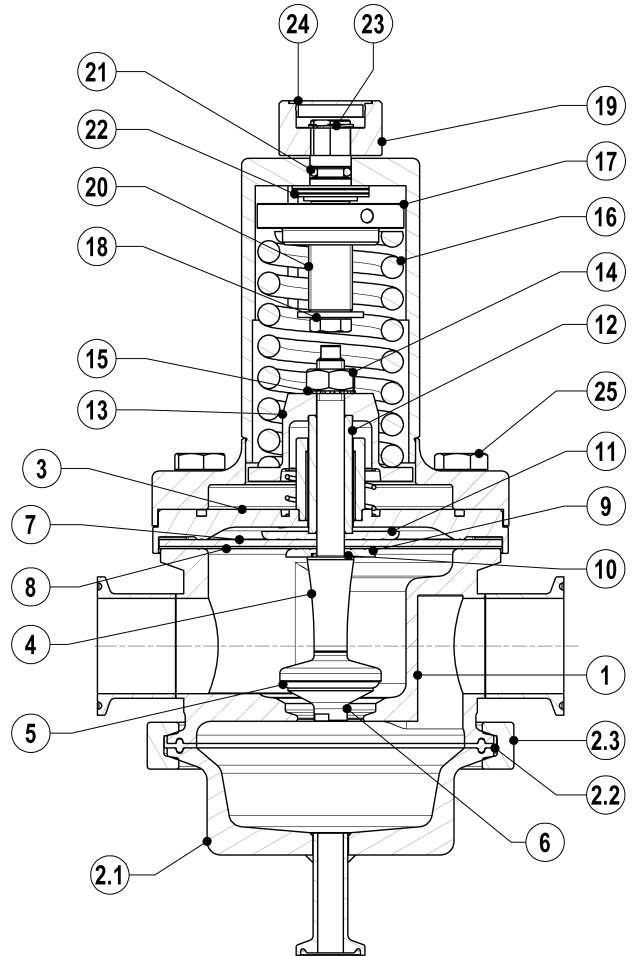

Valve without bottom drain, for clean gases.

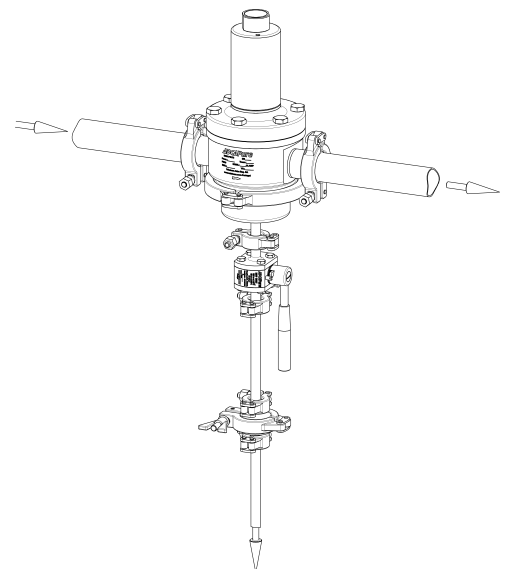

Valve with condensate drain for clean steam.

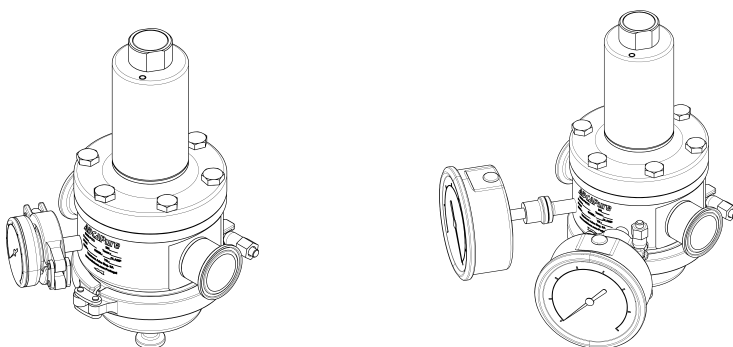

Optional pressure gauge connections.

ORDERING CODES PS173

Valve model	PS17D	4	4	T	M	I	X	X	X	DI	32
PS173 – AISI 316L / 1.4404 Diaphragm pressure sustaining valve with drain	PS17D										
PS173 – AISI 316L / 1.4404 Diaphragm pressure sustaining valve without drain	PS17										
Outlet spring range											
0,8 to 1,5 bar		4									
1 to 3 bar		5									
1,5 to 8 bar		7									
Flow capacity											
Kvs – 5,5		4									
Kvs – 8,5		6									
Diaphragm material											
PTFE (Gylon)				T							
Seat material											
Metal to metal (non-standard)					M						
EPDM					E						
PTFE					T						
FPM / Viton					V						
Regulating knob and top cap											
Stainless steel regulating knob						I					
Top cap (adjusting screw sealing)						T					
Stainless steel regulating knob w/ diaphragm cover leakage connection in case of diaphragm failure						L					
Top cap (adjusting screw sealing) w/ diaphragm cover leakage connection in case of diaphragm failure						U					
Gauge port options											
Without gauge ports							X				
Tri-clamp gauge port on the left side (rel. to the flow direction) – downstream pressure – 1 connection							7				
Tri-clamp gauge port on the right side (rel. to the flow direction) – downstream pressure – 1 connection							6				
Tri-clamp gauge port on the left side (rel. to the flow direction) – upstream and downstream press. – 2 conn. a)							9				
Tri-clamp gauge port on the right side (rel. to the flow direct.) – upstream and downstream press. – 2 conn. a)							8				
Tri-clamp gauge port on both sides – downstream pressure – 2 connections							5				
Threaded gauge port on the left side (rel. to the flow direction) – downstream pressure – ISO 7 Rp 1/4"							4				
Threaded gauge port on the right side (rel. to the flow direction) – downstream pressure – ISO 7 Rp 1/4"							3				
Threaded gauge port on left side (rel. to the flow direction) – upstream and downstream press. – 2 conn. – ISO 7 Rp 1/4"							1				
Threaded gauge port on right side (rel. to the flow direction) – upstream/downstream pressure – 2 conn. – ISO 7 Rp 1/4"							0				
Threaded gauge port on both sides – downstream pressure – ISO 7 Rp 1/4"							2				
Threaded gauge port on the left side (rel. to the flow direction) – downstream pressure – 1/4" NPT							W				
Threaded gauge port on the right side (rel. to the flow direction) – downstream pressure – 1/4" NPT							Y				
Threaded gauge port on left side (rel. to the flow direction) – upstream and downstream press. – 2 conn. – 1/4" NPT							U				
Threaded gauge port on right side (rel. to the flow direction) – upstream and downstream pressure – 2 conn. – 1/4" NPT							V				
Threaded gauge port on both sides – downstream pressure – 1/4" NPT							Z				
Surface finish b)											
Standard surface finish							X				
Mirror mechanical polished external surfaces (SF1)							P				
Electropolished internal wetted parts (SF5)							E				
Special features											
None								X			
Degreased for oxygen								O			
Pipe connection											
Clamp ferrule ASME BPE										D	
Clamp ferrule DIN (DIN 32676-A)										F	
Clamp ferrule ISO (DIN 32676-B)										E	
ETO according to ASME BPE										DI	
ETO according to DIN 11866-A (DIN 11850-2)										FI	
ETO according to ISO 1127-1										EI	
Size											
DN 32 (available with ISO connections only)											32
11/2" or DN 40											40
2" or DN 50 (not available with ISO connections)											50
Special valves / Extras											
Full description or additional codes have to be added in case of non-standard combination											E

a) Under special request and after approval of technical solution; a) Consult IS PV20.00 for further details and other surface finish options.